

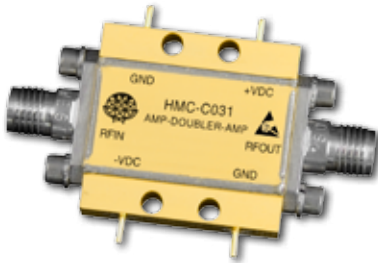

GaAs MMIC x2 ACTIVE FREQUENCY MULTIPLIER MODULE, 6 - 10 GHz OUTPUT



Typical Applications

The HMC-C031 is suitable for:

- Wireless Local Loop
- Point-to-Point & VSAT Radios
- Test Instrumentation
- Military & Space

Features

- High Output Power: +17 dBm
- Low Input Power Drive: -2 to +6 dBm
- 100 KHz SSB Phase Noise: -140 dBc/Hz
- Single Supply: +5V @ 90 mA
- Hermetically Sealed Module
- Field Replaceable SMA Connectors
- 55 °C to +85 °C Operating Temperature

Functional Diagram

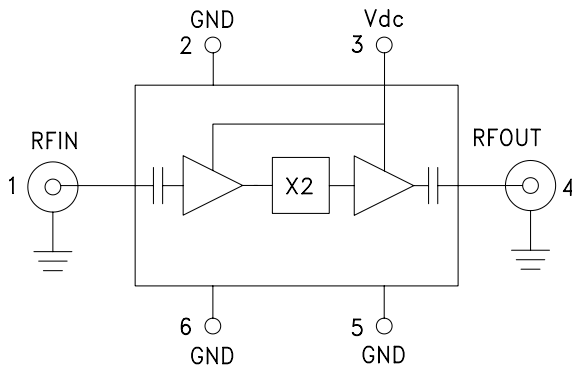

General Description

The HMC-C031 is a x2 active broadband frequency multiplier utilizing GaAs PHEMT technology in a miniature hermetic module. When driven by a 3 dBm signal, the multiplier provides +17 dBm typical output power from 6 to 10 GHz. The Fo and 3Fo isolations are 12 dBc with respect to output signal level. This frequency multiplier features DC blocked I/O's, and is ideal for use in LO multiplier chains for Pt to Pt & VSAT Radios yielding reduced parts count vs. traditional approaches. The low additive SSB Phase Noise of -140 dBc/Hz at 100 kHz offset helps maintain good system noise performance.

Electrical Specifications, $T_A = +25^\circ C$, Vdc = +5V, 3 dBm Drive Level

Parameter	Min.	Typ.	Max.	Units
Frequency Range, Input	3 - 5			GHz
Frequency Range, Output	6 - 10			GHz
Output Power	14	17		dBm
Fo Isolation (with respect to output level)		12		dBc
3Fo Isolation (with respect to output level)		12		dBc
Input Return Loss		20		dB
Output Return Loss		14		dB
SSB Phase Noise (100 kHz Offset)		-140		dBc/Hz
Supply Current		90		mA



GaAs MMIC x2 ACTIVE FREQUENCY MULTIPLIER MODULE, 6 - 10 GHz OUTPUT

Output Power vs. Temperature @ 3 dBm Drive Level

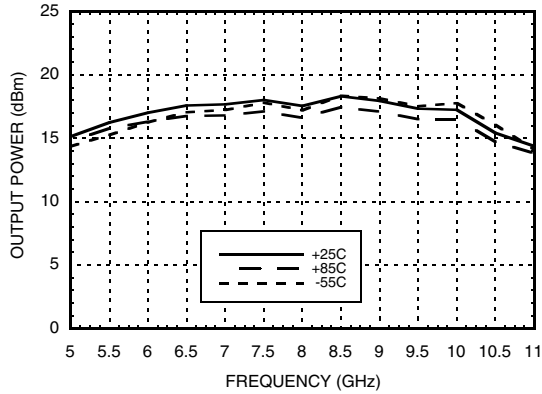

Output Power vs. Drive Level

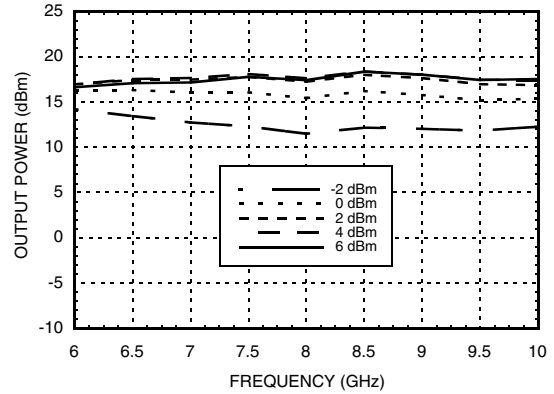

Output Power vs. Supply Voltage @ 3 dBm Drive Level

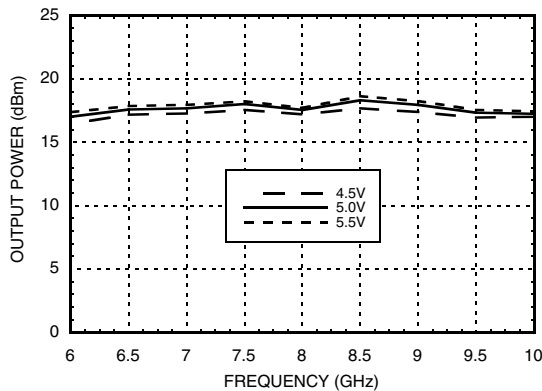

Isolation @ 3 dBm Drive Level

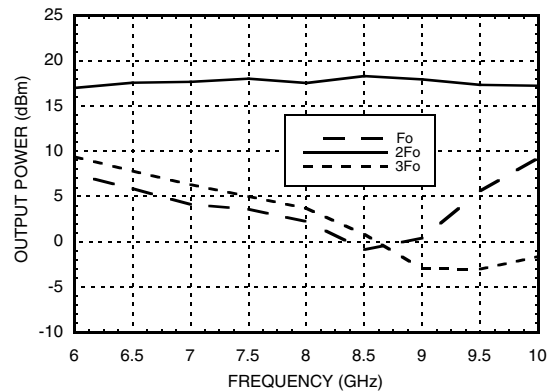

Output Power vs. Input Power

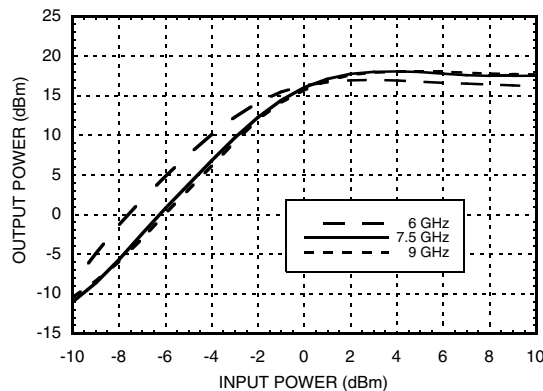



GaAs MMIC x2 ACTIVE FREQUENCY MULTIPLIER MODULE, 6 - 10 GHz OUTPUT

Input Return Loss vs. Temperature @ 0 dBm Drive Level

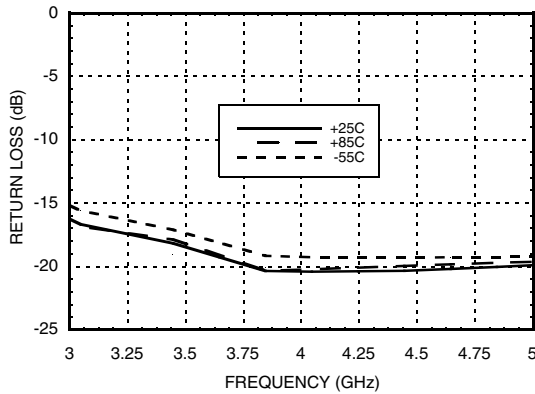

Output Return Loss vs. Temperature @ 0 dBm Drive Level

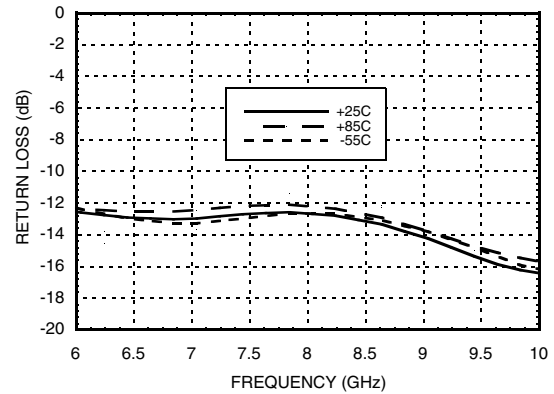

Absolute Maximum Ratings

RF Input (Vdc = +5V)	+13 dBm
Bias Supply Voltage (Vdc)	+6 Vdc
Storage Temperature	-65 to +150 °C
Operating Temperature	-55 to +85 °C

Typical Supply Current vs. Vdd

Vdd (Vdc)	Idd (mA)
4.5	89
5.0	90
5.5	91

Note:
Multiplier will operate over full voltage range shown above.



**ELECTROSTATIC SENSITIVE DEVICE
OBSERVE HANDLING PRECAUTIONS**

Pin Description

Pin Number	Function	Description	Interface Schematic
1	RFIN and RF Ground	Pin is AC coupled and matched to 50 Ohms. RFIN uses a female SMA connector.	
2, 5, 6	GND	One of these pins must be connected to power supply ground.	
3	Vdc	Power supply voltage for the amplifier includes a 7.5V zener diode for over voltage and negative voltage protection	
4	RFOUT and RF Ground	Pin is AC coupled and matched to 50 Ohms. RFOUT uses a female SMA connector.	



GaAs MMIC x2 ACTIVE FREQUENCY MULTIPLIER MODULE, 6 - 10 GHz OUTPUT

Outline Drawing

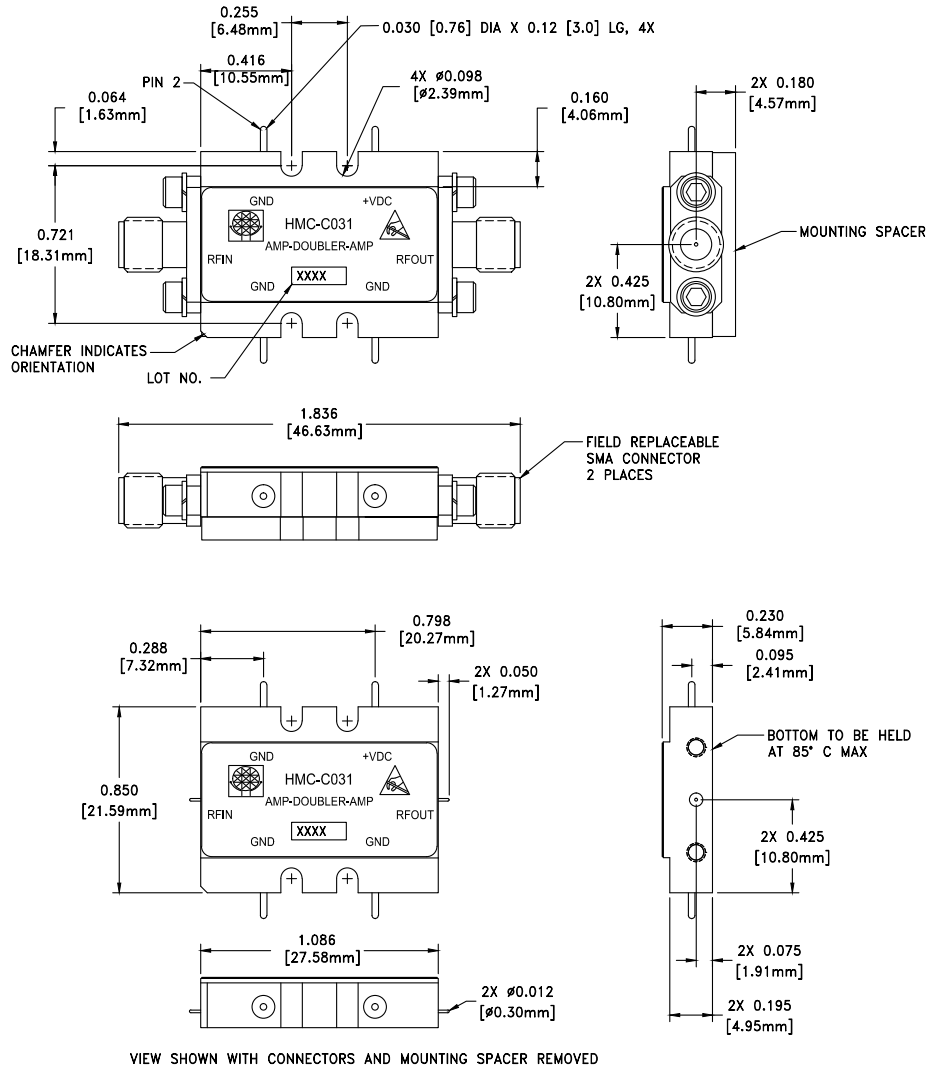

Package Information

Package Type	C-10
Package Weight [1]	18.7 gms [2]
Spacer Weight	3.3 gms [2]

[1] Includes the connectors

[2] \pm 1 gms Tolerance

NOTES:

1. PACKAGE, LEADS, COVER MATERIAL: KOVAR™
2. FINISH: GOLD PLATE OVER NICKEL PLATE
3. ALL DIMENSIONS ARE IN INCHES [MILLIMETERS]
4. TOLERANCES:
 - 4.1 .XX = \pm 0.02
 - 4.2 .XXX = \pm 0.010
5. FIELD REPLACEABLE 2.92mm CONNECTORS TENSOLITE 231CCSF OR EQUIVALENT