

Typical Applications

- 4.8V AMPS Cellular Handsets
- 4.8V CDMA/AMPS Handsets
- 4.8V JCDMA/TACS Handsets
- Driver Amplifier in Cellular Base Stations
- Portable Battery-Powered Equipment

Product Description

The RF2132 is a high power, high efficiency linear amplifier IC. The device is manufactured on an advanced Gallium Arsenide Heterojunction Bipolar Transistor (HBT) process, and has been designed for use as the final RF amplifier in dual-mode 4-cell CDMA/AMPS handheld digital cellular equipment, spread-spectrum systems, and other applications in the 800MHz to 950MHz band. The device is self-contained with 50Ω input and the output can be easily matched to obtain optimum power, efficiency, and linearity characteristics over varying supply and control voltages.

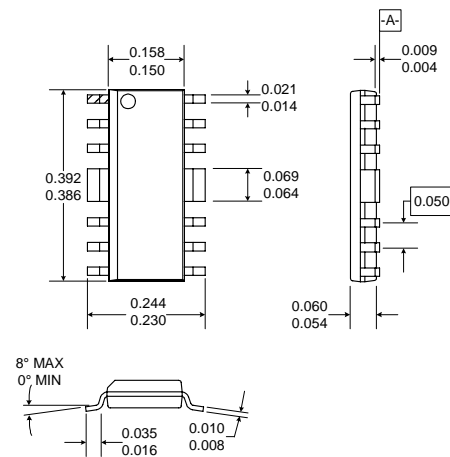

Optimum Technology Matching® Applied

- Si BJT GaAs HBT GaAs MESFET
 Si Bi-CMOS SiGe HBT Si CMOS

Package Style: Standard Batwing

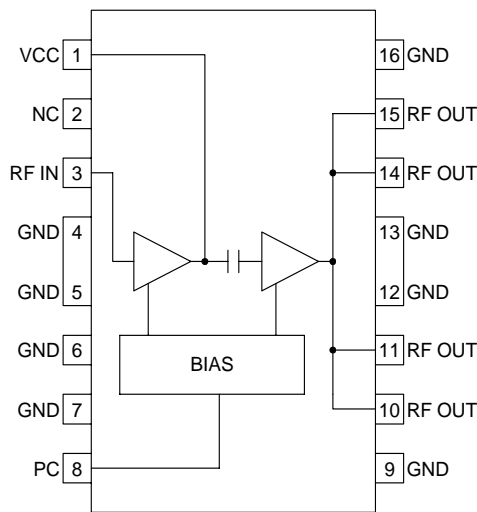

Functional Block Diagram

Features

- Single 4.2V to 5.0V Supply
- Up to 29 dBm Linear Output Power
- 29dB Gain With Analog Gain Control
- 45% Linear Efficiency
- On-board Power Down Mode
- 800MHz to 950MHz Operation

Ordering Information

- RF2132 Linear Power Amplifier
 RF2132 PCBA Fully Assembled Evaluation Board

RF Micro Devices, Inc.
7628 Thorndike Road
Greensboro, NC 27409, USA

Tel (336) 664 1233
Fax (336) 664 0454
<http://www.rfmd.com>

RF2132

2

POWER AMPLIFIERS

Absolute Maximum Ratings

Parameter	Rating	Unit
Supply Voltage (No RF)	-0.5 to +8.0	V _{DC}
Supply Voltage (P _{OUT} <32dBm)	-0.5 to +5.0	V _{DC}
Power Control Voltage (V _{PC})	-0.5 to +5.0 or V _{CC}	V
DC Supply Current	800	mA
Input RF Power	+12	dBm
Output Load VSWR	10:1	
Storage Temperature	-40 to +150	°C
Junction Temperature	200	°C



Caution! ESD sensitive device.

RF Micro Devices believes the furnished information is correct and accurate at the time of this printing. However, RF Micro Devices reserves the right to make changes to its products without notice. RF Micro Devices does not assume responsibility for the use of the described product(s).

Parameter	Specification			Unit	Condition
	Min.	Typ.	Max.		
Overall					T=25 °C, V _{CC} =4.8V, V _{PC} =4.0V, Freq=824MHz to 849MHz
Usable Frequency Range	800	824 to 849	950	MHz	
Linear Gain	27	29	31	dB	
Total Linear Efficiency	40	45		%	
Efficiency at Max Output	50	55		%	
OFF Isolation	23	27		dB	V _{PC} =0V, P _{IN} =+6dBm
Second Harmonic		-30		dBc	Including Second Harmonic Trap
Maximum Linear Output Power		28.5	29		IS-95A CDMA Modulation
Adjacent Channel Power Rejection @ 885 kHz		-46	-44	dBc	P _{out} = 28 dBm
Adjacent Channel Power Rejection @ 1.98 MHz		-58	-56	dBc	ACPR can be improved by trading off efficiency. P _{out} = 28 dBm
Maximum CW Output Power	31.5	32		dBm	
Operating Case Temperature	-30		110	°C	P _{out} = 31 dBm, Efficiency = 55%
Ambient Operating Temperature	-30		100	°C	
Junction to Case Thermal Resistance		85		°C/W	
Input VSWR		<2:1			
Output Load VSWR			10:1		No oscillations
Power Down					
Turn On/Off Time			100	ns	
Total Current			10	µA	"OFF" State
V _{PC} "OFF" Voltage	0.2		0.5	V	
V _{PC} "ON" Voltage	3.6	4.0	V _{CC}	V	
Power Supply					
Power Supply Voltage	4.2	4.8	5.0	V	Operating voltage
Idle Current		40	100	mA	V _{PC} =4.0V
Current into VPC pin		15	20	mA	"ON" State

Pin	Function	Description	Interface Schematic
1	VCC1	Power supply for the driver stage, and interstage matching. Shunt inductance is required on this pin, which can be achieved by an inductor to V_{CC} , with a decoupling capacitor on the V_{CC} side. The value of the inductor is frequency dependent; 3.3nH is required for 830MHz, and 1.2nH for 950MHz. Instead of an inductor, a high impedance microstrip line can be used.	
2	NC	Not Connected.	
3	RF IN	RF input. This is a 50Ω input, but the actual input impedance depends on the interstage matching network connected to pin 1. An external DC blocking capacitor is required if this port is connected to a DC path to ground or a DC voltage.	See pin 1.
4	GND	Ground connection. Keep traces physically short and connect immediately to the ground plane for best performance.	
5	GND	Same as pin 4.	
6	GND	Ground for stage 1. Keep traces physically short and connect immediately to ground plane for best performance. This ground should be isolated from the batwing and other ground contacts. See evaluation board layout.	
7	GND	Same as pin 6.	
8	PC	Power Control. When this pin is "low", all circuits are shut off. A "low" is typically 0.5V or less at room temperature. During normal operation this pin is the power control. Control range varies from about 2V for 0dBm to V_{CC} for +31 dBm RF output power. The maximum power that can be achieved depends on the actual output matching. PC should never exceed 5.0V or V_{CC} , whichever is the lowest.	
9	GND	Same as pin 4.	
10	RF OUT	RF Output and power supply for the output stage. The four output pins are combined, and bias voltage for the final stage is provided through these pins. The external path must be kept symmetric until combined to ensure stability. An external matching network is required to provide the optimum load impedance; see the application schematics for details.	
11	RF OUT	Same as pin 10.	See pin 10.
12	GND	Same as pin 4.	
13	GND	Same as pin 4.	
14	RF OUT	Same as pin 10.	See pin 10.
15	RF OUT	Same as pin 10.	See pin 10.
16	GND	Same as pin 4.	

Application Schematic

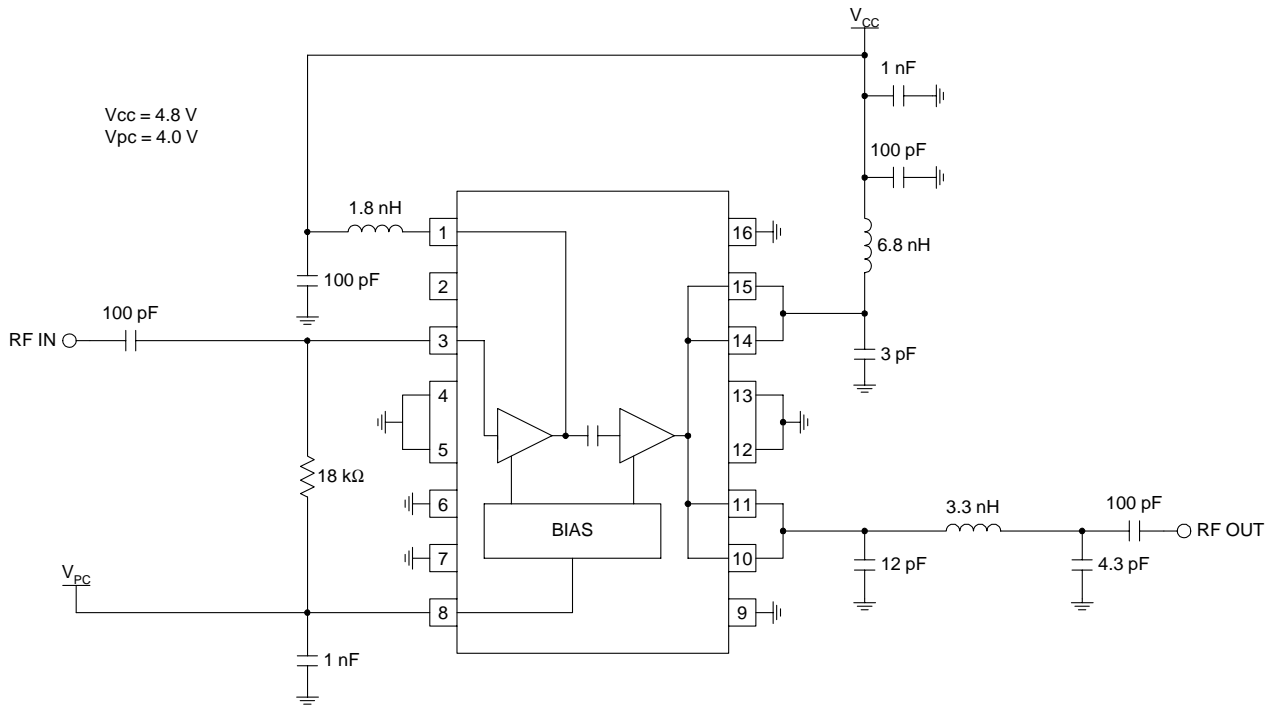

Evaluation Board Schematic (Download [Bill of Materials](http://www.rfmd.com) from www.rfmd.com.)

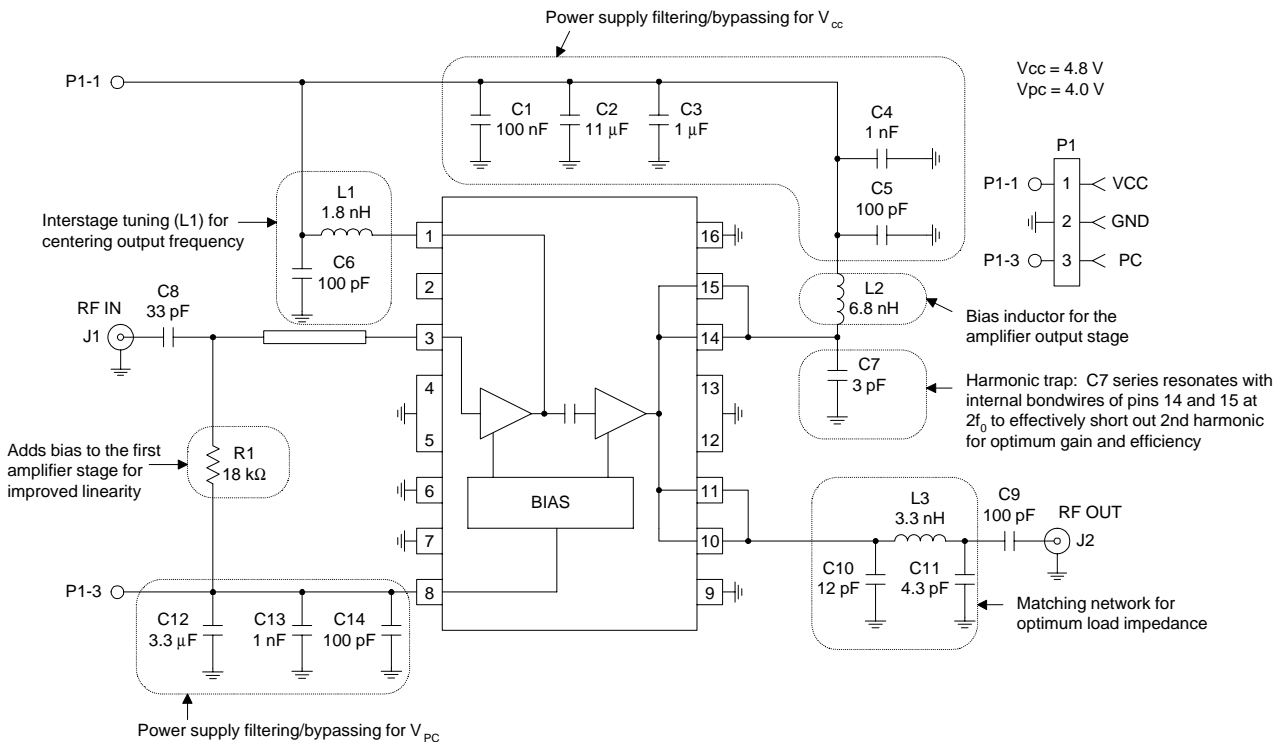

Evaluation Board Layout
2" x 2"

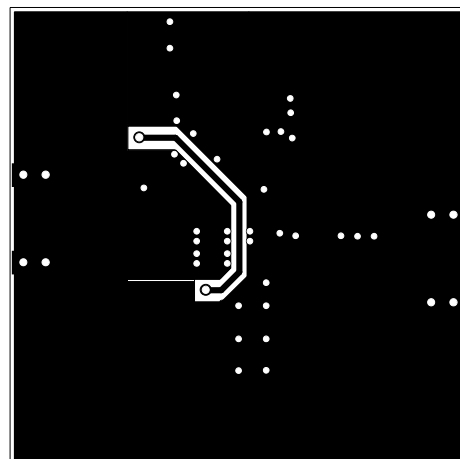
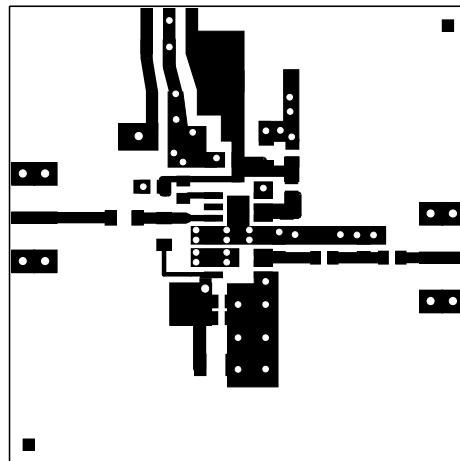
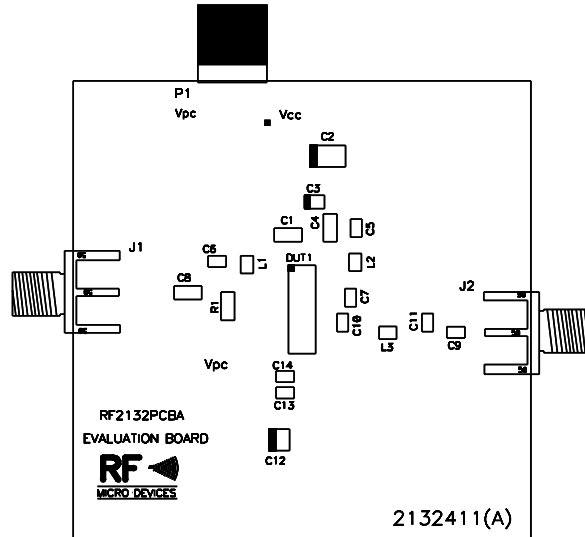

RF2132 Evaluation Board
 Vcc = 4.8 V, Vpc = 4.0 V, Frequency = 836 MHz, IS-95A CDMA

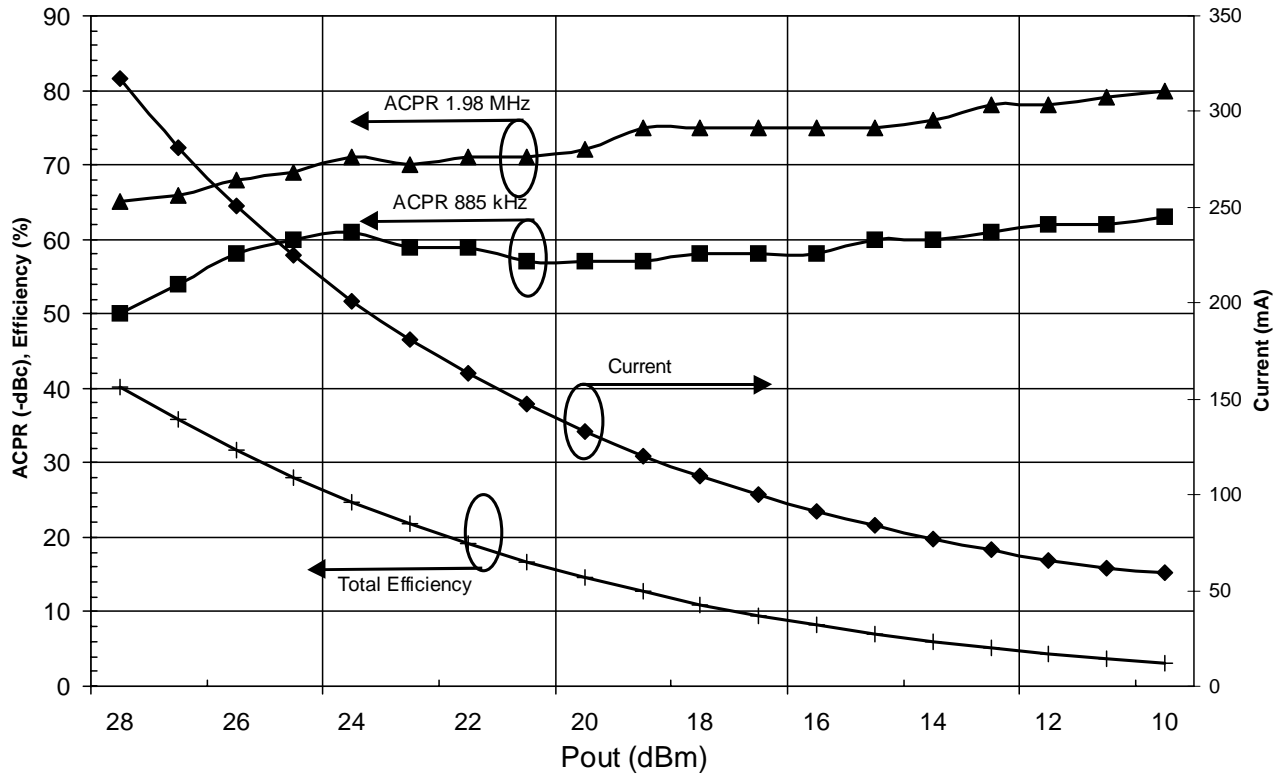

This datasheet has been download from:

www.datasheetcatalog.com

Datasheets for electronics components.