

1K/2K 2.5V CMOS Serial EEPROMs

FEATURES

- Single supply with operation down to 2.5V
- Low power CMOS technology
 - 1 mA active current typical
 - 10 μ A standby current typical at 5.5V
 - 5 μ A standby current typical at 3.0V
- Organized as a single block of 128 bytes (128 x 8) or 256 bytes (256 x 8)
- Two wire serial interface bus, I²C™ compatible
- 100kHz (2.5V) and 400kHz (5V) compatibility
- Self-timed write cycle (including auto-erase)
- Page-write buffer for up to 8 bytes
- 2 ms typical write cycle time for page-write
- Hardware write protect for entire memory
- Can be operated as a serial ROM
- Factory programming (QTP) available
- ESD protection > 3,000V
- **10,000,000 ERASE/WRITE cycles guaranteed on 24LC01B**
- **1,000,000 E/W cycles guaranteed on 24LC02B***
- Data retention > 200 years
- 8 pin DIP or SOIC package
- Available for extended temperature ranges
 - Commercial: 0°C to +70°C
 - Industrial: -40°C to +85°C

DESCRIPTION

The Microchip Technology Inc. 24LC01B and 24LC02B are 1K bit and 2K bit Electrically Erasable PROMs. The devices are organized as a single block of 128 x 8 bit or 256 x 8 bit memory with a two wire serial interface. Low voltage design permits operation down to 2.5 volts with a standby and active currents of only 5 μ A and 1 mA respectively. The 24LC01B and 24LC02B also have page-write capability for up to 8 bytes of data. The 24LC01B and 24LC02B are available in the standard 8-pin DIP and an 8-pin surface mount SOIC package.

PACKAGE TYPE

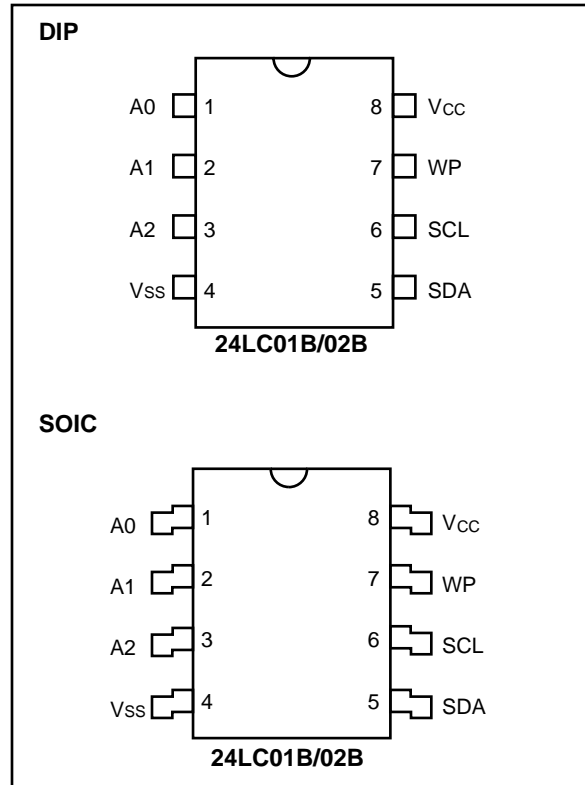

BLOCK DIAGRAM

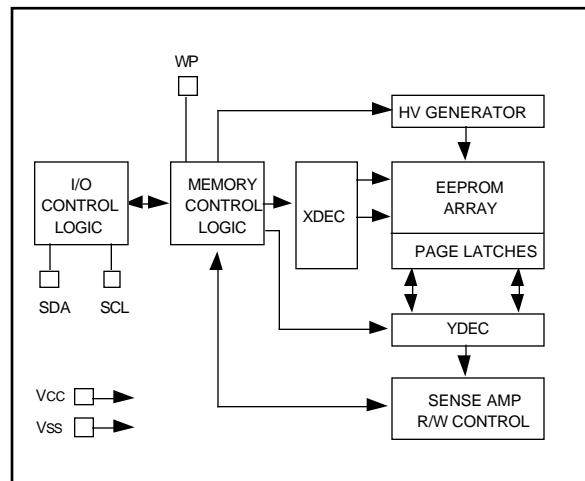

*Future: 10,000,000 E/W cycles guaranteed.

24LC01B/02B

1.0 ELECTRICAL CHARACTERISTICS

Maximum Ratings*

VCC..... 7.0V
 All inputs and outputs w.r.t. VSS -0.6V to VCC +1.0V
 Storage temperature -65°C to +150°C
 Ambient temp. with power applied -65°C to +125°C
 Soldering temperature of leads (10 seconds) ... +300°C
 ESD protection on all pins ≥ 4 kV

*Notice: Stresses above those listed under "Maximum ratings" may cause permanent damage to the device. This is a stress rating only and functional operation of the device at those or any other conditions above those indicated in the operational listings of this specification is not implied. Exposure to maximum rating conditions for extended periods may affect device reliability.

TABLE 1-1: PIN FUNCTION TABLE

Name	Function
VSS	Ground
SDA	Serial Address/Data I/O
SCL	Serial Clock
WP	Write Protect Input
VCC	+2.5V to 5.5V Power Supply
A0, A1, A2	No Internal Connection

TABLE 1-2: DC CHARACTERISTICS

Parameter	Symbol	Min.	Max.	Units	Conditions
WP, SCL and SDA pins: High level input voltage	V _{IH}	.7 VCC		V	
Low level input voltage	V _{IL}		.3 VCC	V	
Hysteresis of Schmidt trigger inputs	V _{HYS}	.05 VCC	—	V	Note 1
Low level output voltage	V _{OL}		.40	V	I _{OL} = 3.0 mA, VCC = 2.5V
Input leakage current	I _{LI}	-10	10	μA	V _{IN} = .1V to 5.5V
Output leakage current	I _{LO}	-10	10	μA	V _{OUT} = .1V to 5.5V
Pin capacitance (all inputs/outputs)	C _{IN} , C _{OUT}	—	10	pF	VCC = 5.0V (Note 1) T _{amb} = 25°C, F _{CLK} = 1 MHz
Operating current	I _{CC} Write	—	3	mA	VCC = 5.5V, SCL = 400 kHz
	I _{CC} Read	—	1	mA	
Standby current	I _{CCS}	—	30	μA	VCC = 3.0V, SDA = SCL = VCC
			100	μA	VCC = 5.5V, SDA = SCL = VCC

Note 1: This parameter is periodically sampled and not 100% tested.

FIGURE 1-1: BUS TIMING START/STOP

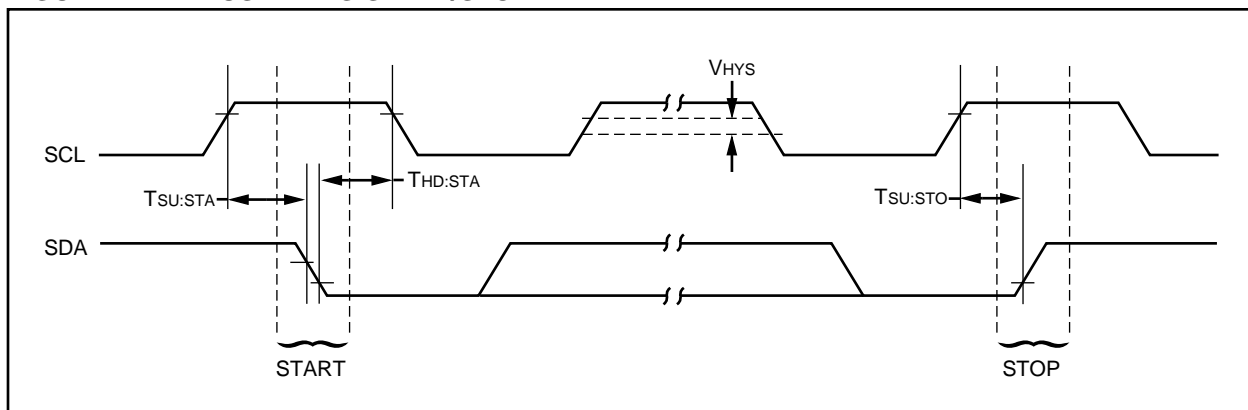

TABLE 1-3: AC CHARACTERISTICS

Parameter	Symbol	STANDARD MODE		Vcc = 4.5 - 5.5V FAST MODE		Units	Remarks
		Min.	Max.	Min.	Max.		
Clock frequency	FCLK	—	100	—	400	kHz	
Clock high time	T _{HIGH}	4000	—	600	—	ns	
Clock low time	T _{LOW}	4700	—	1300	—	ns	
SDA and SCL rise time	T _R	—	1000	—	300	ns	Note 2
SDA and SCL fall time	T _F	—	300	—	300	ns	Note 2
START condition hold time	T _{HD:STA}	4000	—	600	—	ns	After this period the first clock pulse is generated
START condition setup time	T _{SU:STA}	4700	—	600	—	ns	Only relevant for repeated START condition
Data input hold time	T _{HD:DAT}	0	—	0	—	ns	Note 1
Data input setup time	T _{SU:DAT}	250	—	100	—	ns	
STOP condition setup time	T _{SU:STO}	4000	—	600	—	ns	
Output valid from clock	T _{A A}	—	3500	—	900	ns	Note 1
Bus free time	T _{B U F}	4700	—	1300	—	ns	Time the bus must be free before a new transmission can start
Output fall time from V _{I H} minimum to V _{I L} maximum	T _{O F}	—	250	20 + 0.1 CB	250	ns	Note 2, CB ≤ 100 pF
Input filter spike suppression (SDA and SCL pins)	T _{S P}	—	50	—	50	ns	Note 3
Write cycle time	T _{W R}	—	10	—	10	ms	Byte or Page mode

Note 1: As a transmitter, the device must provide an internal minimum delay time to bridge the undefined region (minimum 300 ns) of the falling edge of SCL to avoid unintended generation of START or STOP conditions.

Note 2: Not 100% tested. CB = total capacitance of one bus line in pF.

Note 3: The combined T_{S P} and V_{H Y S} specifications are due to new Schmitt trigger inputs which provide improved noise spike suppression. This eliminates the need for a T_I specification for standard operation.

FIGURE 1-2: BUS TIMING DATA

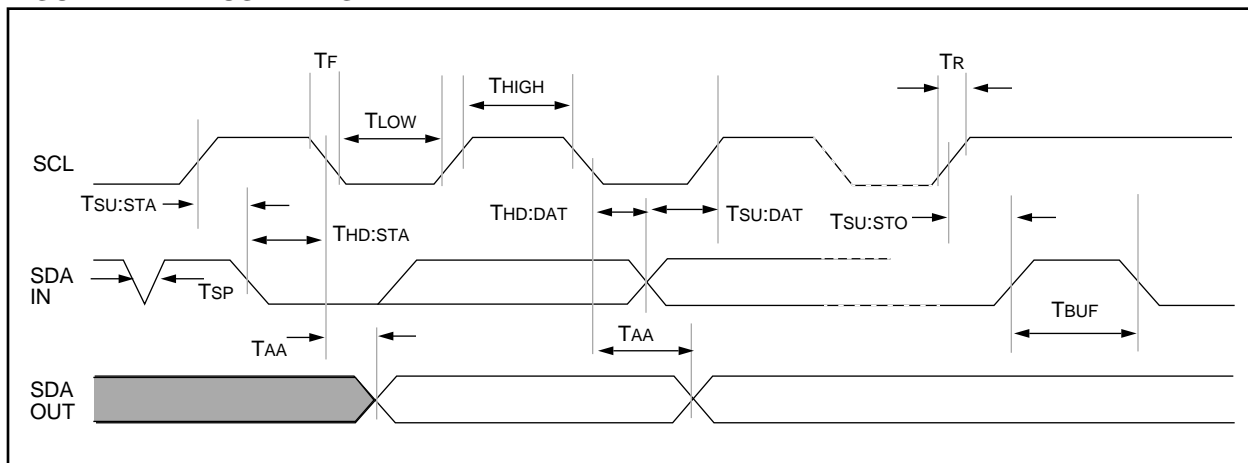

2.0 FUNCTIONAL DESCRIPTION

The 24LC01B/02B supports a bidirectional two wire bus and data transmission protocol. A device that sends data onto the bus is defined as transmitter, and a device receiving data as receiver. The bus has to be controlled by a master device which generates the serial clock (SCL), controls the bus access, and generates the START and STOP conditions, while the 24LC01B/02B works as slave. Both master and slave can operate as transmitter or receiver but the master device determines which mode is activated.

3.0 BUS CHARACTERISTICS

The following **bus protocol** has been defined:

- Data transfer may be initiated only when the bus is not busy.
- During data transfer, the data line must remain stable whenever the clock line is HIGH. Changes in the data line while the clock line is HIGH will be interpreted as a START or STOP condition.

Accordingly, the following bus conditions have been defined (see Figure 3-1).

3.1 Bus not Busy (A)

Both data and clock lines remain HIGH.

3.2 Start Data Transfer (B)

A HIGH to LOW transition of the SDA line while the clock (SCL) is HIGH determines a START condition. All commands must be preceded by a START condition.

3.3 Stop Data Transfer (C)

A LOW to HIGH transition of the SDA line while the clock (SCL) is HIGH determines a STOP condition. All operations must be ended with a STOP condition.

3.4 Data Valid (D)

The state of the data line represents valid data when, after a START condition, the data line is stable for the duration of the HIGH period of the clock signal.

The data on the line must be changed during the LOW period of the clock signal. There is one clock pulse per bit of data.

Each data transfer is initiated with a START condition and terminated with a STOP condition. The number of the data bytes transferred between the START and STOP conditions is determined by the master device and is theoretically unlimited, although only the last sixteen will be stored when doing a write operation. When an overwrite does occur it will replace data in a first in first out fashion.

3.5 Acknowledge

Each receiving device, when addressed, is obliged to generate an acknowledge after the reception of each byte. The master device must generate an extra clock pulse which is associated with this acknowledge bit.

Note: The 24LC01B/02B does not generate any acknowledge bits if an internal programming cycle is in progress.

The device that acknowledges has to pull down the SDA line during the acknowledge clock pulse in such a way that the SDA line is stable LOW during the HIGH period of the acknowledge related clock pulse. Of course, setup and hold times must be taken into account. A master must signal an end of data to the slave by not generating an acknowledge bit on the last byte that has been clocked out of the slave. In this case, the slave must leave the data line HIGH to enable the master to generate the STOP condition.

FIGURE 3-1: DATA TRANSFER SEQUENCE ON THE SERIAL BUS

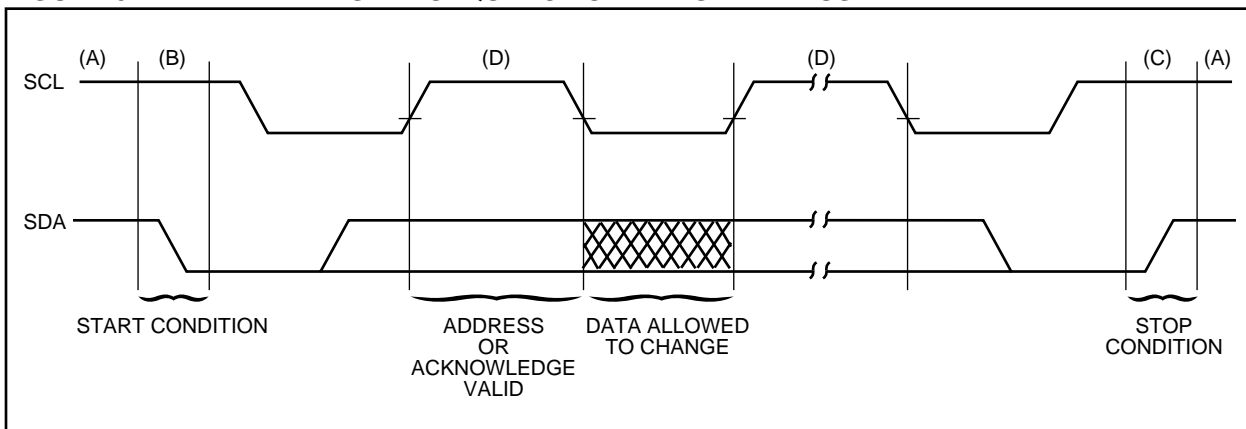

4.0 BUS CHARACTERISTICS

4.1 Slave Address

The 24LC01B/02B are software-compatible with older devices such as 24C01A, 24C02A, 24LC01, and 24LC02. A single 24LC02B can be used in place of two 24LC01's, for example, without any modifications to software. The "chip select" portion of the control byte becomes a don't care.

After generating a START condition, the bus master transmits the slave address consisting of a 4-bit device code (1010) for the 24LC01B/02B, followed by three don't care bits.

The eighth bit of slave address determines if the master device wants to read or write to the 24LC01B/02B (see Figure 4-1).

The 24LC01B/02B monitors the bus for its corresponding slave address all the time. It generates an acknowledge bit if the slave address was true and it is not in a programming mode.

Operation	Control Code	Chip Select	R/ \bar{W}
Read	1010	XXX	1
Write	1010	XXX	0

FIGURE 4-1: CONTROL BYTE ALLOCATION

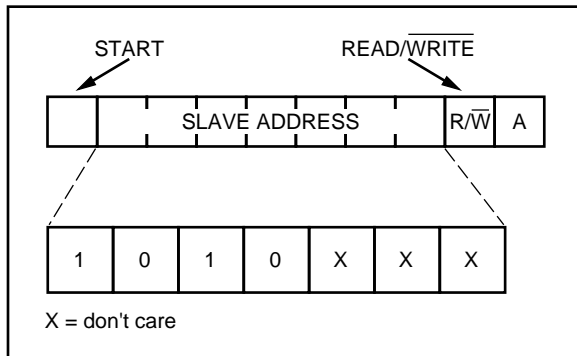

5.0 WRITE OPERATION

5.1 Byte Write

Following the start signal from the master, the device code (4 bits), the don't care bits (3 bits), and the R/ \bar{W} bit which is a logic low is placed onto the bus by the master transmitter. This indicates to the addressed slave receiver that a byte with a word address will follow after it has generated an acknowledge bit during the ninth clock cycle. Therefore the next byte transmitted by the master is the word address and will be written into the address pointer of the 24LC01B/02B. After receiving another acknowledge signal from the 24LC01B/02B the master device will transmit the data word to be written into the addressed memory location. The 24LC01B/02B acknowledges again and the master generates a stop condition. This initiates the internal write cycle, and during this time the 24LC01B/02B will not generate acknowledge signals (see Figure 5-1).

5.2 Page Write

The write control byte, word address and the first data byte are transmitted to the 24LC01B/02B in the same way as in a byte write. But instead of generating a stop condition the master transmits up to eight data bytes to the 24LC01B/02B which are temporarily stored in the on-chip page buffer and will be written into the memory after the master has transmitted a stop condition. After the receipt of each word, the three lower order address pointer bits are internally incremented by one. The higher order five bits of the word address remains constant. If the master should transmit more than eight words prior to generating the stop condition, the address counter will roll over and the previously received data will be overwritten. As with the byte write operation, once the stop condition is received an internal write cycle will begin (see Figure 8-1).

FIGURE 5-1: BYTE WRITE

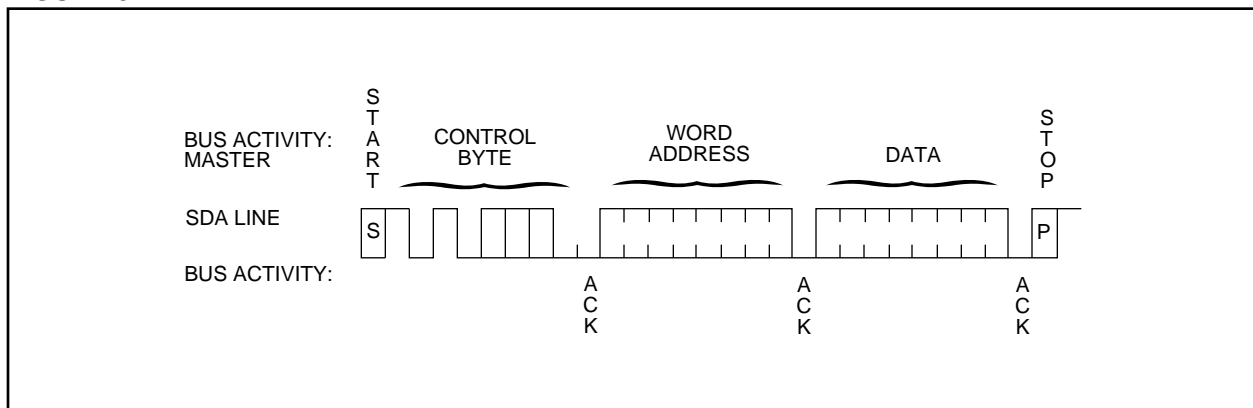

6.0 ACKNOWLEDGE POLLING

Since the device will not acknowledge during a write cycle, this can be used to determine when the cycle is complete (this feature can be used to maximize bus throughput). Once the stop condition for a write command has been issued from the master, the device initiates the internally timed write cycle. ACK polling can be initiated immediately. This involves the master sending a start condition followed by the control byte for a write command ($R/\bar{W} = 0$). If the device is still busy with the write cycle, then no ACK will be returned. If the cycle is complete, then the device will return the ACK and the master can then proceed with the next read or write command. See Figure 6-1 for flow diagram.

FIGURE 6-1: ACKNOWLEDGE POLLING FLOW

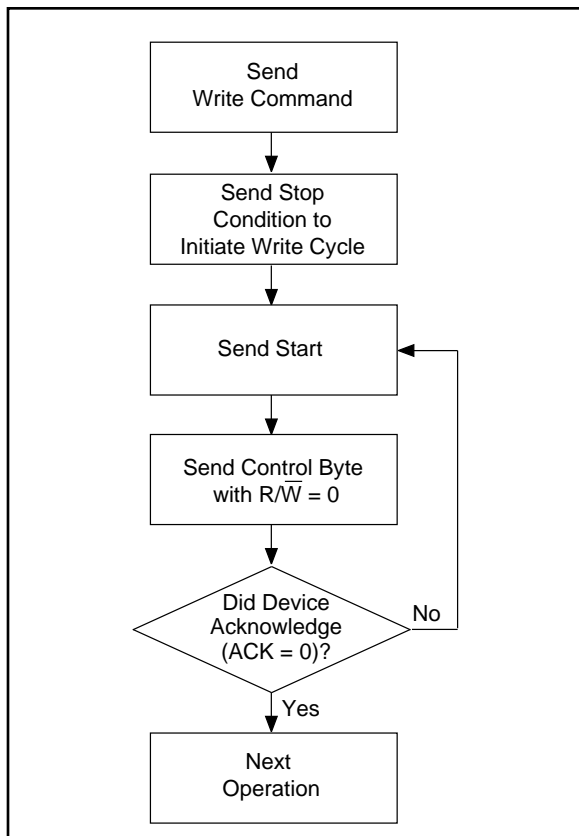

7.0 WRITE PROTECTION

The 24LC01B/02B can be used as a serial ROM when the WP pin is connected to VCC. Programming will be inhibited and the entire memory will be write-protected.

8.0 READ OPERATION

Read operations are initiated in the same way as write operations with the exception that the R/\bar{W} bit of the slave address is set to one. There are three basic types of read operations: current address read, random read, and sequential read.

8.1 Current Address Read

The 24LC01B/02B contains an address counter that maintains the address of the last word accessed, internally incremented by one. Therefore, if the previous access (either a read or write operation) was to address n , the next current address read operation would access data from address $n + 1$. Upon receipt of the slave address with R/\bar{W} bit set to one, the 24LC01B/02B issues an acknowledge and transmits the eight bit data word. The master will not acknowledge the transfer but does generate a stop condition and the 24LC01B/02B discontinues transmission (see Figure 8-2).

8.2 Random Read

Random read operations allow the master to access any memory location in a random manner. To perform this type of read operation, first the word address must be set. This is done by sending the word address to the 24LC01B/02B as part of a write operation. After the word address is sent, the master generates a start condition following the acknowledge. This terminates the write operation, but not before the internal address pointer is set. Then the master issues the control byte again but with the R/\bar{W} bit set to a one. The 24LC01B/02B will then issue an acknowledge and transmits the eight bit data word. The master will not acknowledge the transfer but does generate a stop condition and the 24LC01B/02B discontinues transmission (see Figure 8-3).

FIGURE 8-1: PAGE WRITE

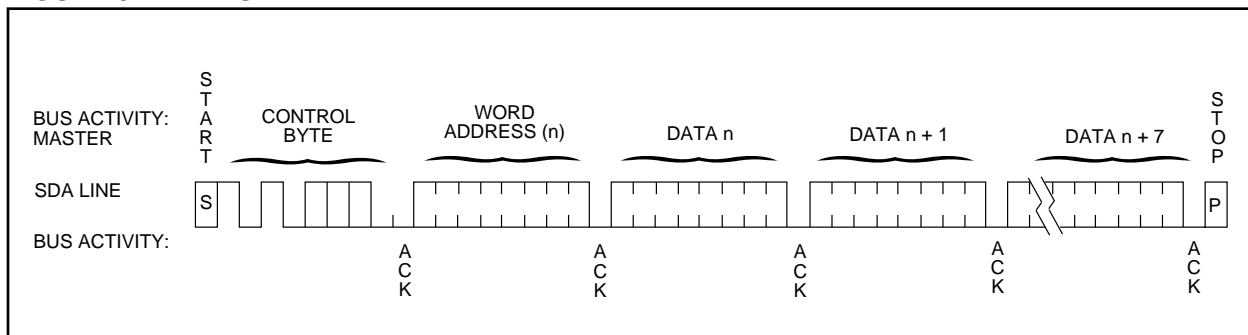

FIGURE 8-2: CURRENT ADDRESS READ

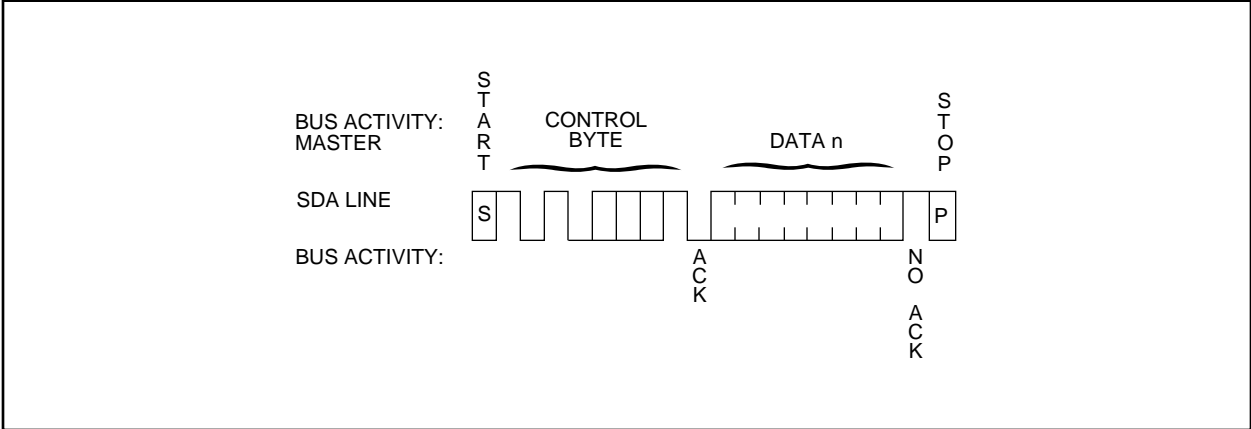
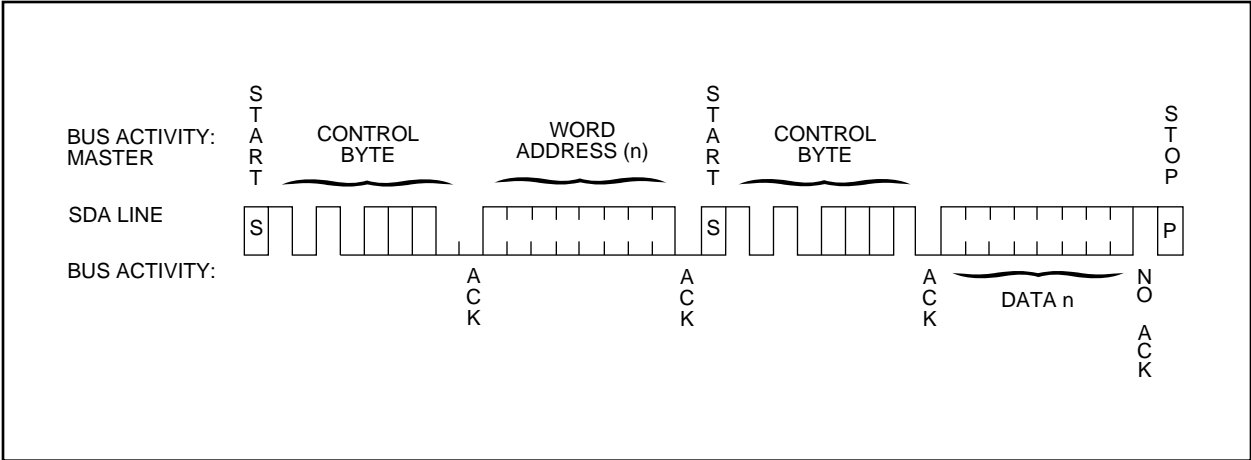

FIGURE 8-3: RANDOM READ



NOTES:

24LC01B/02B

24LC01B/02B Product Identification System

To order or to obtain information, e.g., on pricing or delivery, please use the listed part numbers, and refer to the factory or the listed sales offices.

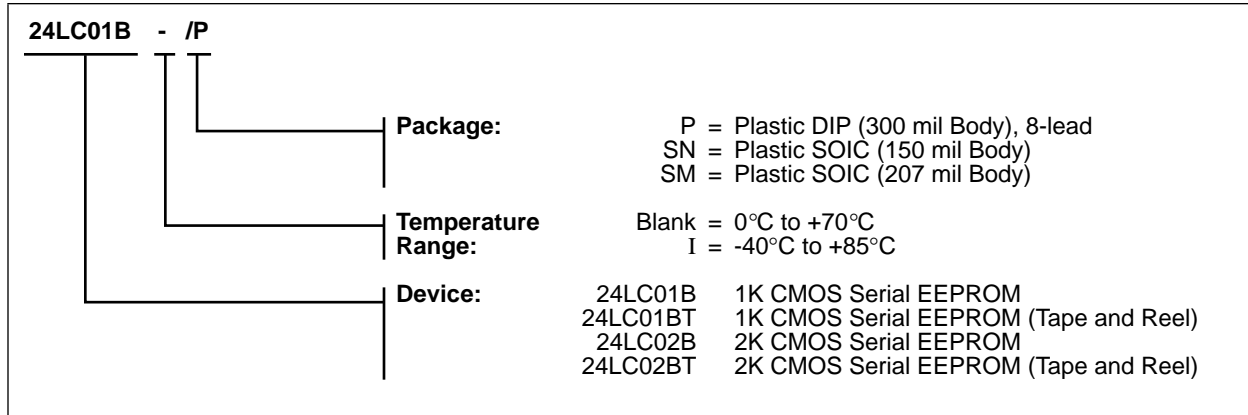

AMERICAS

Corporate Office

Microchip Technology Inc.
2355 West Chandler Blvd.
Chandler, AZ 85224-6199
Tel: 602 786-7200 Fax: 602 786-7277
Technical Support: 602 786-7627
Web: <http://www.mchip.com/biz/mchip>

Atlanta

Microchip Technology Inc.
500 Sugar Mill Road, Suite 200B
Atlanta, GA 30350
Tel: 770 640-0034 Fax: 770 640-0307

Boston

Microchip Technology Inc.
5 Mount Royal Avenue
Marlborough, MA 01752
Tel: 508 480-9990 Fax: 508 480-8575

Chicago

Microchip Technology Inc.
333 Pierce Road, Suite 180
Itasca, IL 60143
Tel: 708 285-0071 Fax: 708 285-0075

Dallas

Microchip Technology Inc.
14651 Dallas Parkway, Suite 816
Dallas, TX 75240-8809
Tel: 214 991-7177 Fax: 214 991-8588

Dayton

Microchip Technology Inc.
35 Rockridge Road
Englewood, OH 45322
Tel: 513 832-2543 Fax: 513 832-2841

Los Angeles

Microchip Technology Inc.
18201 Von Karman, Suite 455
Irvine, CA 92715
Tel: 714 263-1888 Fax: 714 263-1338

New York

Microchip Technology Inc.
150 Motor Parkway, Suite 416
Hauppauge, NY 11788
Tel: 516 273-5305 Fax: 516 273-5335

AMERICAS (continued)

San Jose

Microchip Technology Inc.
2107 North First Street, Suite 590
San Jose, CA 95131
Tel: 408 436-7950 Fax: 408 436-7955

ASIA/PACIFIC

Hong Kong

Microchip Technology
Unit No. 3002-3004, Tower 1
Metroplaza
223 Hing Fong Road
Kwai Fong, N.T. Hong Kong
Tel: 852 2 401 1200 Fax: 852 2 401 3431

Korea

Microchip Technology
168-1, Youngbo Bldg. 3 Floor
Samsung-Dong, Kangnam-Ku,
Seoul, Korea
Tel: 82 2 554 7200 Fax: 82 2 558 5934

Singapore

Microchip Technology
200 Middle Road
#10-03 Prime Centre
Singapore 188980
Tel: 65 334 8870 Fax: 65 334 8850

Taiwan

Microchip Technology
10F-1C 207
Tung Hua North Road
Taipei, Taiwan, ROC
Tel: 886 2 717 7175 Fax: 886 2 545 0139

EUROPE

United Kingdom

Arizona Microchip Technology Ltd.
Unit 6, The Courtyard
Meadow Bank, Furlong Road
Bourne End, Buckinghamshire SL8 5AJ
Tel: 44 0 1628 851077 Fax: 44 0 1628 850259

France

Arizona Microchip Technology SARL
2 Rue du Buisson aux Fraises
91300 Massy - France
Tel: 33 1 69 53 63 20 Fax: 33 1 69 30 90 79

Germany

Arizona Microchip Technology GmbH
Gustav-Heinemann-Ring 125
D-81739 Muenchen, Germany
Tel: 49 89 627 144 0 Fax: 49 89 627 144 44

Italy

Arizona Microchip Technology SRL
Centro Direzionale Colleoni
Palazzo Pegaso Ingresso No. 2
Via Paracelso 23, 20041
Agrate Brianza (MI) Italy
Tel: 39 039 689 9939 Fax: 39 039 689 9883

JAPAN

Microchip Technology Intl. Inc.
Benex S-1 6F
3-18-20, Shin Yokohama
Kohoku-Ku, Yokohama
Kanagawa 222 Japan
Tel: 81 45 471 6166 Fax: 81 45 471 6122

9/5/95



MICROCHIP

Printed in the USA, 9/95
© 1995, Microchip Technology Incorporated

"Information contained in this publication regarding device applications and the like is intended through suggestion only and may be superseded by updates. No representation or warranty is given and no liability is assumed by Microchip Technology Incorporated with respect to the accuracy or use of such information, or infringement of patents arising from such use or otherwise. Use of Microchip's products as critical components in life support systems is not authorized except with express written approval by Microchip. No licenses are conveyed, implicitly or otherwise, under any intellectual property rights." The Microchip logo and name are registered trademarks of Microchip Technology Inc. All rights reserved. All other trademarks mentioned herein are the property of their respective companies.

